



PRODUCTS SPECIFICATION

LED REMOTE CONTROLLER

LD-RC SERIES

Made by	Checked by	Version
Ms. Katie	Ms. Jane	2009.8.29



LED Controller introduction

Features:

Working temperature : **-20°C ~ 60°C**

Working vltage:DC12V

Measurement:107*65*24mm

Rated load current:8A* 3CHANNEL

Rated current:8A

This controller can adjustable 9 pattern.

Photos



Assembly drawing(Controller)

Top View

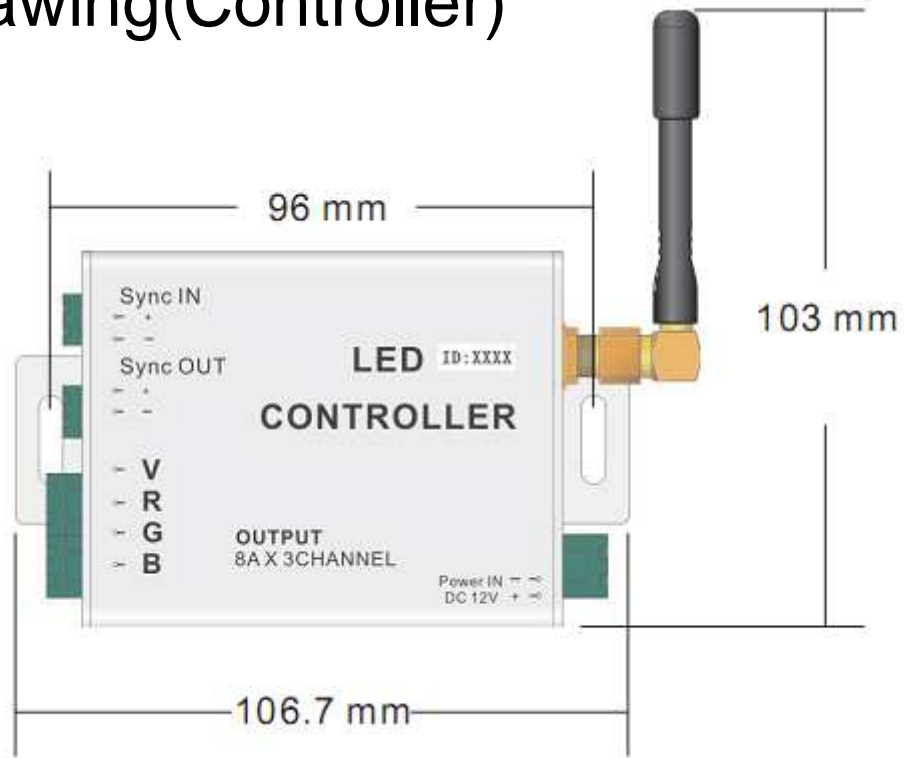

Section

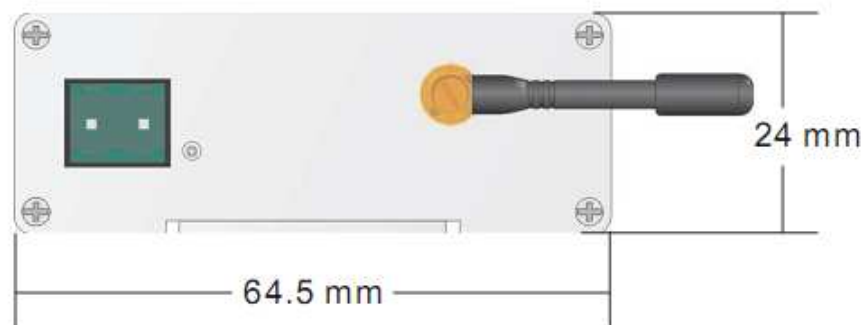

Operation Temperature: -20°C ~ 60°C

Store Temperature: -30°C ~ 80°C

Assembly drawing

Top View

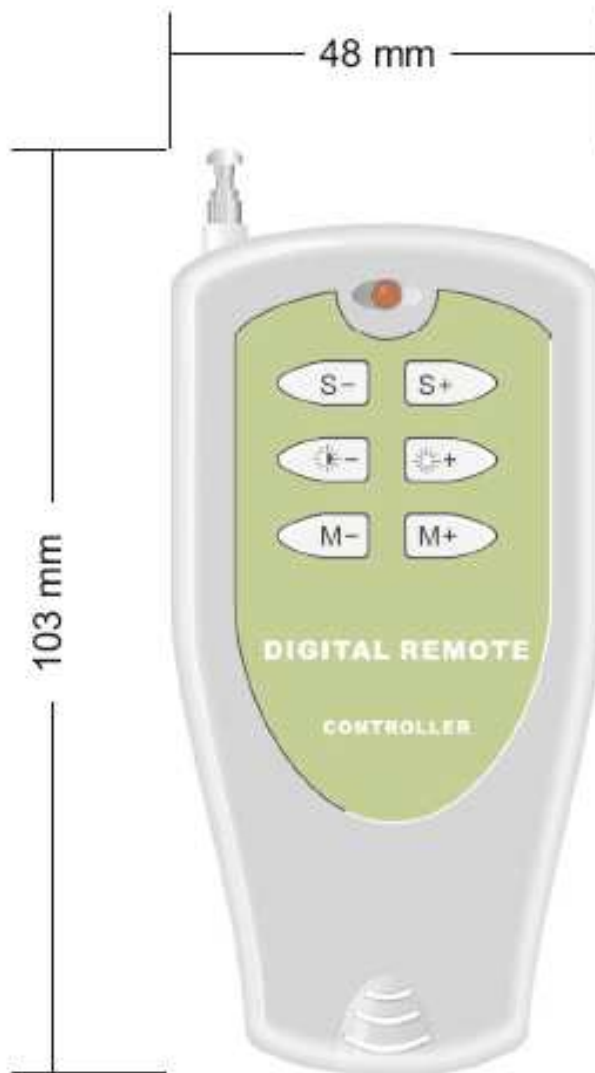

Section



LED Controller/Remote control device

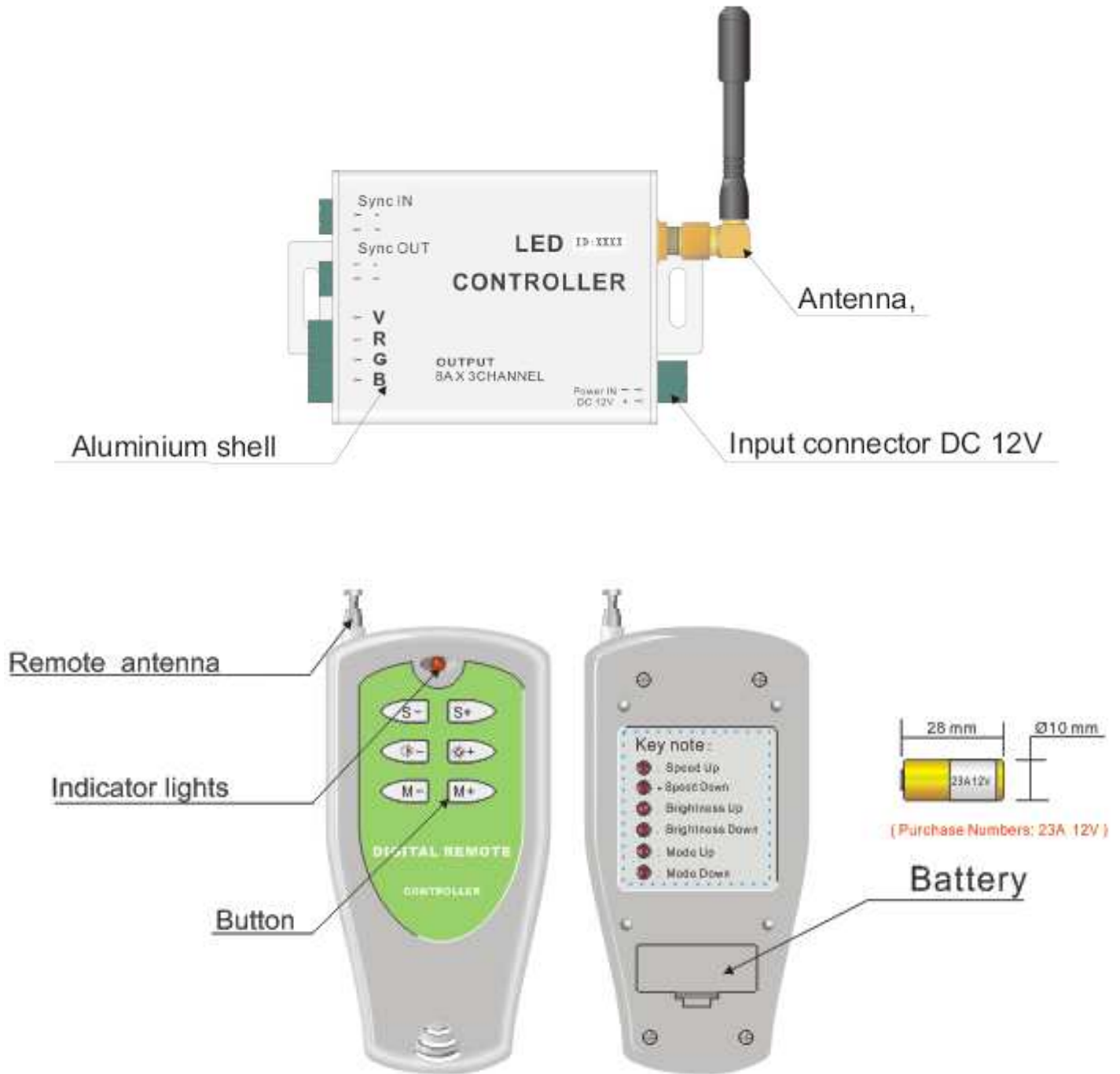

Controller Mode Instruction:

❖ The controller contains 9 adjusted modes, they are color gradational changing, color immediately changing,

Red, Green, blue, yellow, cyan, purple, white;

❖ Notes: When the controller is on, the modes will not reset automatically, and it would be the same mode as the

last time you turned it off. So, you can use “M+” and “M-” buttons to choose “forward the adjusting direction” and “reverse the adjusting direction”.

How to connect Controller

Below shows you how to connect the Controller to power supplies.

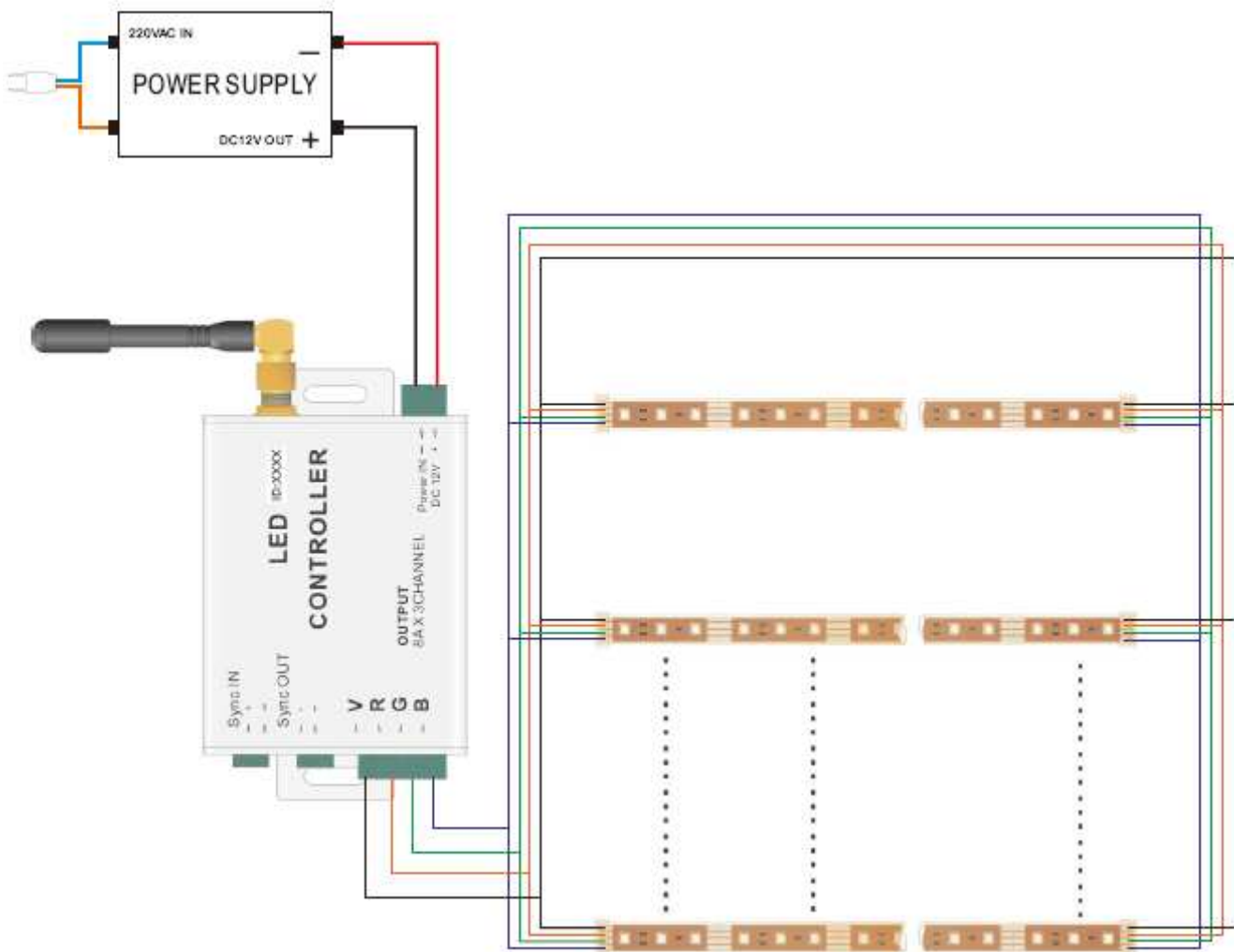

Note:

- 1、 This kind of connection works to the RGB LED products, such as LED flexible strips, LED Modules, LED Rigid Bars and so on.
- 2、 If the LED products' Power is more than the LED controller's load, we suggest you to use Amplifiers . Before the installation, please check the working Voltage and powers of the LED products ,the LED controller, Amplifiers .(Make sure the LED products , the Amplifiers ,dimmer and Controller's working voltage are the same DC 12V or the same DC 24V, and make sure the power of the LED products are less that the controller and Amplifiers' power load.)(Details of amplifier specifications)